

THIS DRAWING IS UNPUBLISHED. RELEASED FOR PUBLICATION  
 © COPYRIGHT - By - ALL RIGHTS RESERVED.

LOC	DIST	REVISIONS			
P	LTR	DESCRIPTION	DATE	OWN	APVD
CM	53	AF2	REVISED PER ECR 12-013810	240SEPT12	JR TM

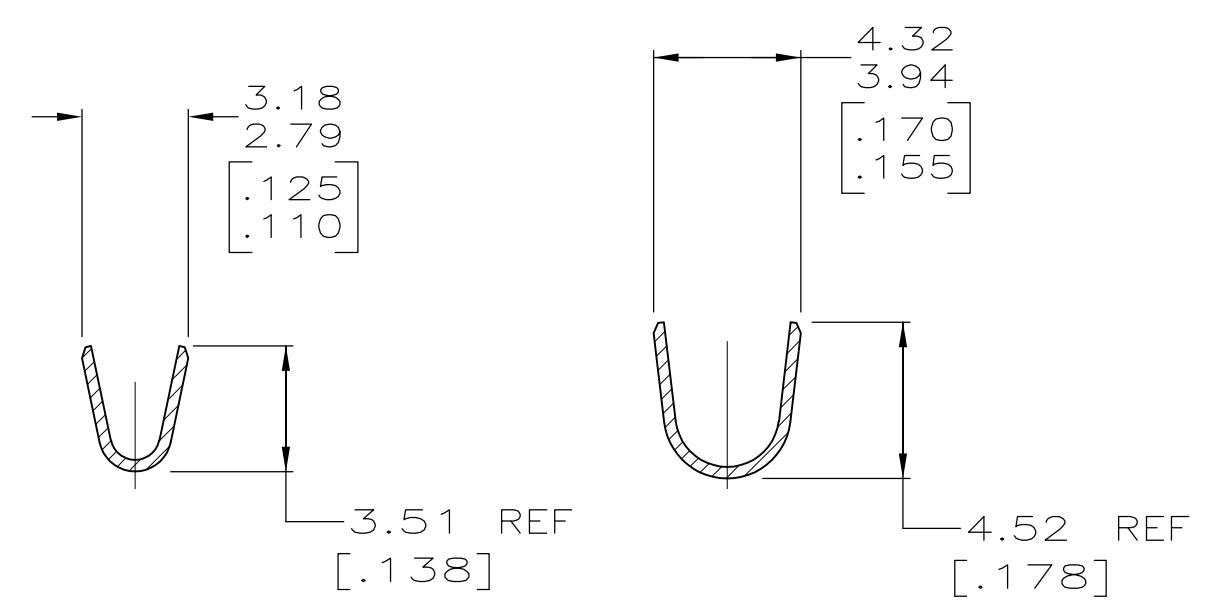
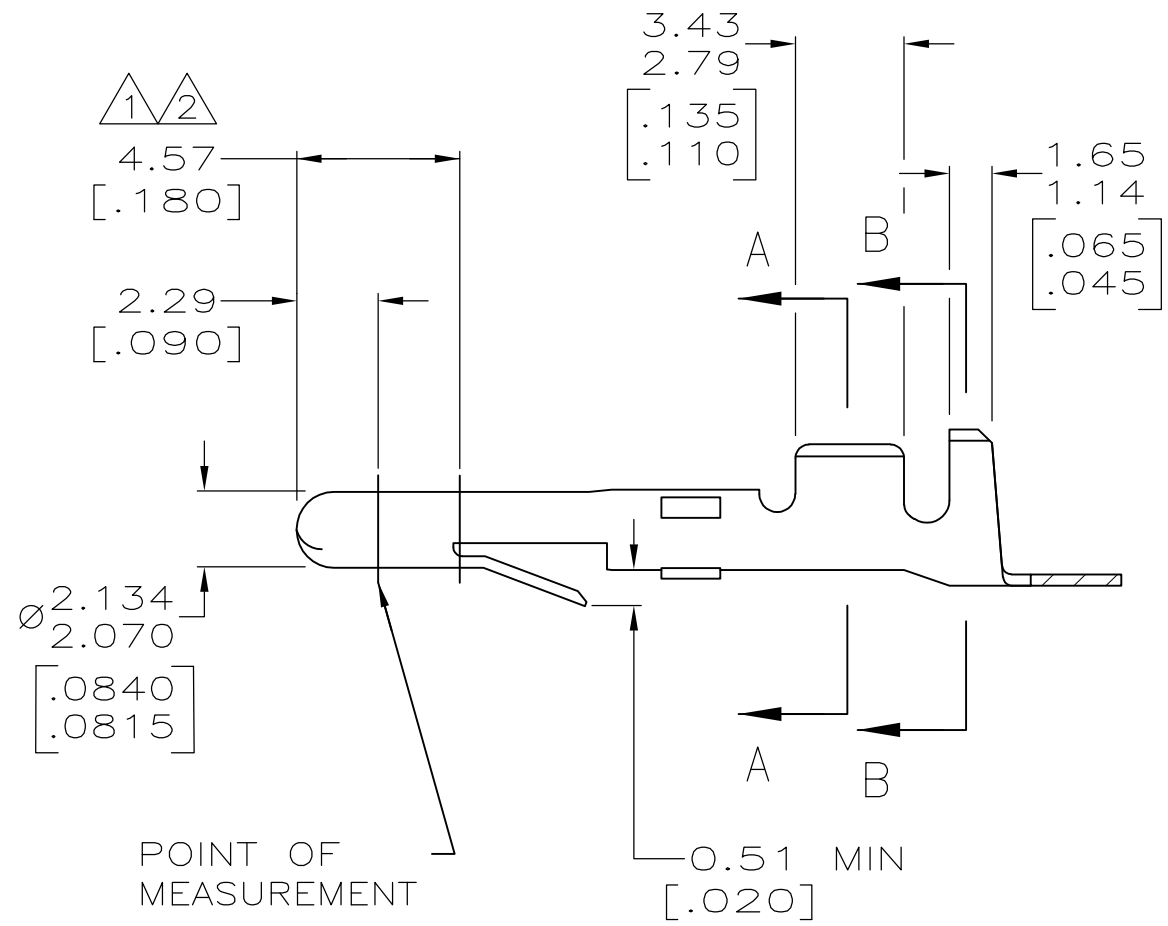
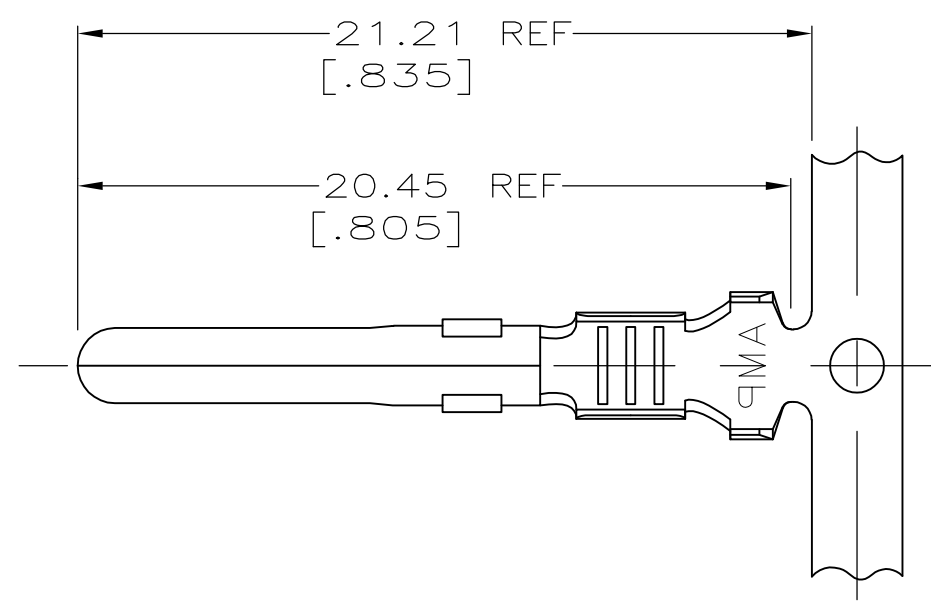

**METRIC**

- ① PLATE OVERALL WITH 0.00127 [.000050] MIN NICKEL, THEN TIP PLATE WITH 0.00076 [.000030] MIN GOLD IN THE MATING AREA.
- ② PLATE OVERALL WITH 0.00127 [.000050] MIN NICKEL, THEN PLATE IN THE MATING AREA AND STRIPE THE INSIDE OF THE WIRE BARREL WITH 0.00076 [.000030] MIN GOLD.
- 3. WIRE RANGE: 0.5 - 2 mm<sup>2</sup> [20 - 14 AWG].
- 4. INSULATION RANGE: 3.30 [.130] MAX DIA.
- 5. APPLICATION TYPE: MINI.
- 6. DIMENSIONS IN BRACKETS ARE IN INCHES.

①	0.33 [.012]	BRASS	61118-7
②	0.33 [.012]	PH BRZ	61118-6
③	0.33 [.012]	BRASS	61118-5
PRE-TIN	0.33 [.012]	PH BRZ	61118-4
-	0.33 [.012]	BRASS	61118-2
PRE-TIN	0.33 [.012]	BRASS	61118-1
FINISH	MATERIAL		PART NO

THIS DRAWING IS A CONTROLLED DOCUMENT.		DWN T. BECK 11-20-92	<b>STE</b> TE Connectivity	
DIMENSIONS: mm[INCHES]		CHK R. SWING 11-20-92		
TOLERANCES UNLESS OTHERWISE SPECIFIED:		APVD D. SELF 12-9-92	NAME PIN, MATE-N-LOK™	
0 PLC ± -		PRODUCT SPEC	-	
1 PLC ± -		APPLICATION SPEC	-	
2 PLC ± 0.25 [.010]		WEIGHT	-	
3 PLC ± -		SIZE	A2	
4 PLC ± -		CAGE CODE	00779	
ANGLES ± ± -		DRAWING NO	G-61118	
FINISH		RESTRICTED TO	-	
SEE TABLE		CUSTOMER DRAWING	SCALE	5:1
SEE TABLE		SHEET	1 OF 1	
		REV	AF2	